



Geyserswise Withdrawable Element

Geyserswise CC
151 Cook Street
Goodwood
7460
Tel: 021 592 4903
www.geyserswise.co.za
Meinhard Fourie Cell 082
681 6413



Geyserswise cc • **members** Nicolene Fourie, André Meinhard Fourie, Elizabeth Louise Fourie

postal address Post Net, Private Bag X103, Suite 239, N1 City, 7463 • **physical address** 151 Cook Street, Goodwood, 7460, Western Cape
tel 086 104 3973 • **fax** 086 664 3973 • **email** info@geyserswise.co.za • **web** www.geyserswise.co.za • **reg no** 2004/083059/23 • **VAT no** 4550224515



1. Introduction

Thank you for giving Geyserswise the opportunity to present information on our withdrawable element for water heaters.

Geyserswise has been operating in the hot water industry since 2004. We have developed a host of products specifically with the aim of reducing electricity consumption when heating liquids. These products include:

- Geyserswise TSE Intelligent geyser controller (over 150,000 units sold)
- Geyserswise Max Intelligent controller (over 200,000 units sold)
- Geyserswise Dual Intelligent controller
- Geyserswise Online Platform for managing geysers
- PV Hot water heating system
- PTC Energy saving immersion heating elements

All products are designed in-house by designers with many years' experience in the hot water industry.

All our intelligent controllers are tested in terms of SANS181 and all our immersion heating elements are tested in terms of SANS514.

2. Immersion Heaters (Hot water Cylinder elements) background

Electric immersion heating elements made with resistance wire are traditionally used as the source of heat in electric geysers. This is the only type of heating element used in geysers within the South African market. When voltage is applied to the resistance wire, it heats up. Heating elements designed to heat water typically operate above 500°C internally. Since the element's resistance measurement is constant, the heat output will be constant regardless of the surroundings.

When an element using resistance wire is subjected to conditions such as scale build up or operation in air due to a water level drop, the heat generated by the wire is not able to dissipate quickly enough. This results in a rapid increase in surface and internal temperatures. These elevated temperatures shorten the element service life and can damage surrounding material such as a plastic tank or piping. From tests conducted in air, tank temperatures can increase to 180°C within two minutes. The resistance wire heating element also failed within 10 minutes.



Geyserswise cc • **members** Nicolene Fourie, André Meinhard Fourie, Elizabeth Louise Fourie

postal address Post Net, Private Bag X103, Suite 239, N1 City, 7463 • **physical address** 151 Cook Street, Goodwood, 7460, Western Cape
tel 086 104 3973 • **fax** 086 664 3973 • **email** info@geyserswise.co.za • **web** www.geyserswise.co.za • **reg no** 2004/083059/23 • **VAT no** 4550224515



3. Problems with traditional hot water cylinder elements

- Currently over 2000 water elements in South Africa are replaced daily
- Failures are mainly due to:
 - Harsh water conditions leading to premature failure of elements
 - Empty water tanks (geysers) leading to ‘burning out’ of the element
 - Premature failure due to cheap imports of resistive heating elements. In many cases materials are not suitable to our water conditions and leads to inefficiencies in electricity consumption to heat hot water
- Each time an element fails, the geyser has to be drained leading to increased **labour cost and water wastage**

4. The Geyserswise Solution

Recognizing the necessity for product refinement Geyserswise developed an advanced immersion heater element that offers inherent safety and improved functionality over typical resistance-wire heaters. The element is constructed of stainless steel and utilizes Positive Thermal Coefficient (PTC) chips as the heat source – this offers a self-limiting capability previously unavailable, and eliminates the possibility of overheating when used properly. This advantageous concept represents a major milestone in immersion water heating both from an Alternating Current (AC) and Direct Current (DC) supply source. The PTC chips also have energy saving capabilities as the resistance decreases as the temperature of the water increases.

The element is also designed in such a way that water does not have to be drained from the geyser when replacing an element leading to a ***saving in time and water.***

The element is also designed for harsh water conditions with an extended life span when compare to traditional resistive heaters.



Geyserswise cc • **members** Nicolene Fourie, André Meinhard Fourie, Elizabeth Louise Fourie

postal address Post Net, Private Bag X103, Suite 239, N1 City, 7463 • **physical address** 151 Cook Street, Goodwood, 7460, Western Cape
tel 086 104 3973 • **fax** 086 664 3973 • **email** info@geyserswise.co.za • **web** www.geyserswise.co.za • **reg no** 2004/083059/23 • **VAT no** 4550224515

a. Graphical Representation

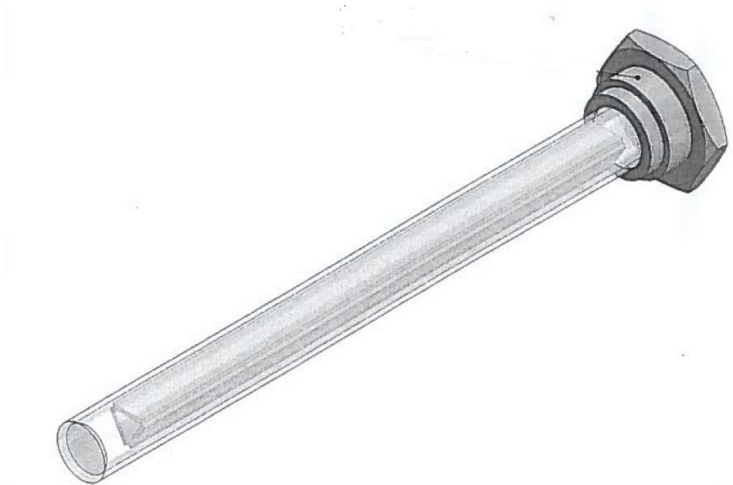

Figure 1 - Element Sleeve

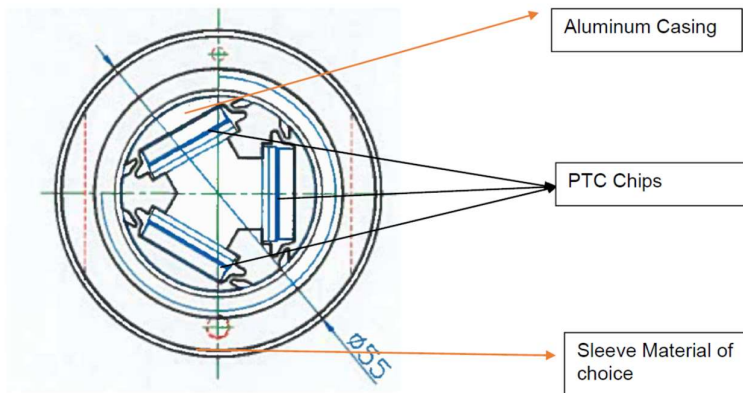

Figure 2 - Inside sleeve, removable housing. Replace electrical component in housing without draining the hot water cylinder





Figure 3 - Fit on flange



Figure 4 - Fit on flange

b. Technical Specifications

	1500 Element	2200W Element	3000W element
Material	Stainless 316	Stainless 316	Stainless 316
Resistance (Ω)	30 - 100	30-100	30-100
Rated Voltage (V)	230	230	230
Max Voltage (V)	265	265	265
Inrush current (A)	<15	<17	<27
Surface Temp ($^{\circ}$C)	240	240	240
Power (W)	1500	2200	3000
Diameter (mm)	35	35	35
Length (mm)	245	305	415





GeyserWise cc • **members** Nicolene Fourie, André Meinhard Fourie, Elizabeth Louise Fourie

postal address Post Net, Private Bag X103, Suite 239, N1 City, 7463 • **physical address** 151 Cook Street, Goodwood, 7460, Western Cape
tel 086 104 3973 • **fax** 086 664 3973 • **email** info@geyserwise.co.za • **web** www.geyserwise.co.za • **reg no** 2004/083059/23 • **VAT no** 4550224515